

PP4001 UNIVERSAL REMOTE CONTROL INTEGRATED CIRCUIT

FEATURES

- Fully Integrated Solution
- Controls Common Home Entertainment Devices From Computer or Microcontroller
- Converts Parallel Word into IR
- Controls any combination of TV/VCR/Cable/Satellite receiver
- Comprehensive IR Code "Library" for Broad Coverage of Home Entertainment Systems
- Visible LED and Status Word Outputs for User "Handshaking"
- Punch-Through Operation

PIN CONFIGURATION

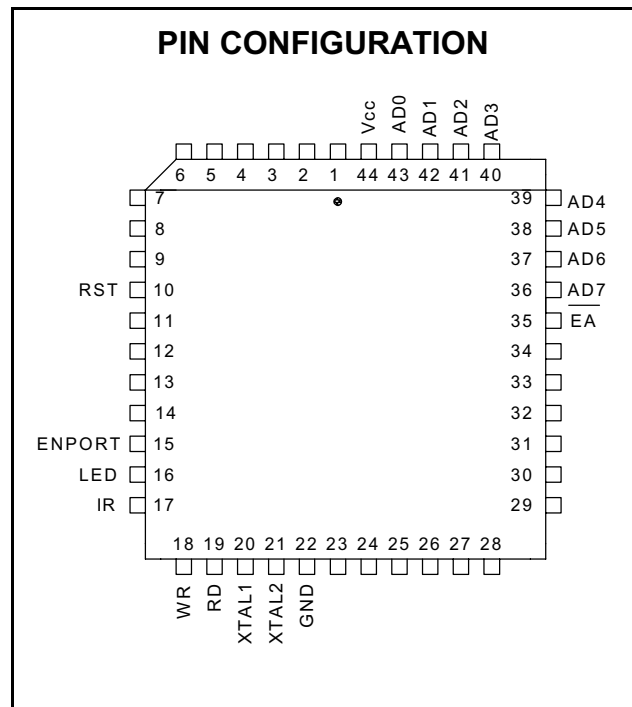

DESCRIPTION

The ISI PP4001 Parallel Port Universal Remote Integrated Circuit (IR Engine) provides a convenient means of controlling entertainment devices, such as TVs, VCRs, satellites and cable

boxes from a computer or microcontroller. The ISI Parallel Port Universal Remote Integrated Circuit converts parallel words into IR control signals for driving infrared diodes.

PROGRAMMING INTERFACE DESCRIPTION

The Parallel Port IR Engine is controlled via a bi-directional parallel tri-state bus interface. A host CPU can manipulate the IR engine by writing

commands in the form of simulated button presses to it. The IR engine will respond by returning status information for every command.



To maintain flow control, the IR engine will not return a status response byte until it has processed the previous command.

The command byte consists of 7 scancode bits and one button-pressed bit.

Command byte to IR engine

D7	D6	D5	D4	D3	D2	D1	D0
Button pressed	Scan Code						

This gives a maximum capacity of 128 buttons. The *button pressed bit* has several purposes.

- ◆ It provides a way to hold down a button for an arbitrarily long period of time.
- ◆ It provides a flow control mechanism between the two asynchronous processors. Some commands are executed very quickly (10s of microseconds) and some are quite slow (100s of milliseconds).
- ◆ It provides a way to distinguish two consecutive identical button presses.

Commands are sent to the IR engine in the form of “virtual” keypad scancodes. The 7 LSBs of the command are the scancode. This gives the system 128 virtual buttons that can be “pressed.” Of these 128 buttons the IR engine uses a subset to represent the buttons on a typical remote control.

After the IR engine has received and acted on a command it will return a status byte. The status byte tells the host processor how the previous scancode was dealt with. It also tells the system that it can send another command. The details of the status byte are covered later in this document.

The IR engine can be configured to transmit IR messages indefinitely, or it can be instructed to transmit an IR message a fixed number of times and then stop. When sending an indefinite length IR message, a ‘*transmitting IR now*’ status message is returned at the start of a transmission. Subsequently, when a button release command is sent, the IR engine completes the current transmission and then it returns the appropriate status.

Special scancodes are available to tell the IR engine to transmit IR message until told to stop, or to send messages a fixed number of times. The auto-repeat range is from 1 to 8 messages. A setting of 0 tells the IR engine to send the message continuously until the button is released.

When the transmit N times feature is used, the IR engine will not return a status byte until the IR transmission is completely sent (N times) so that the system knows that the transmission is complete.

The following is a list of scancodes that a system can send to the IR engine. Codes are in hexadecimal and do **not** include the button-pressed bit.



Code	Code	Function	Notes
0	00h	#0	
1	01h	#1	
2	02h	#2	
3	03h	#3	
4	04h	#4	
5	05h	#5	
6	06h	#6	
7	07h	#7	
8	08h	#8	
9	09h	#9	
10	0Ah	ENTER	
11	0Bh	MUTE	
12	0Ch	VOL+	
13	0Dh	VOL-	
14	0Eh	CH+	
15	0Fh	CH-	
16	10h	REWIND	
17	11h	PLAY	
18	12h	FF	
19	13h	RECORD	
20	14h	STOP	
21	15h	PAUSE	
22	16h	POWER	
23	17h	RECALL	
24	18h	TV/VCR	
64	40h	PROGRAM	Returns 2, 3 flashes or error code
65	41h	SOURCE 1	Returns 1 flash
66	42h	SOURCE 2	Returns 1 flash
67	43h	SOURCE 3	Returns 1 flash
68	44h	SOURCE 4	Returns 1 flash

Code	Code	Function	Notes
80	50h	Transmit IR continuously until told to stop	(Return 0 flashes)
81	51h	Transmit IR once	(Return 1 flash)
82	52h	Transmit IR twice	(Return 2 flashes)
83	53h	Transmit IR three times	(Return 3 flashes)
84	54h	Transmit IR four times	(Return 4 flashes)
85	55h	Transmit IR five times	(Return 5 flashes)
86	56h	Transmit IR six times	(Return 6 flashes)
87	57h	Transmit IR seven times	(Return 7 flashes)
88	58h	Transmit IR eight times	(Return 8 flashes)
96	60h	Return firmware major	(Returns 1 flash)
97	61h	Return firmware minor	(Returns 1 flash)
98	62h	Return database revision major	(Returns 1 flash)
99	63h	Return database revision minor	(Returns 1 flash)

Source is used to identify the device being controlled (TV, VCR, Cable etc).

Before any IR messages can be sent, the IR engine must be programmed with the type of applicane is being controlled. The programming sequence is as follows:



- ◆ Source
- ◆ PROGRAM
- ◆ 3-digit-ISI-number
- ◆ PROGRAM

A test point lead on the IR engine can be connected to a visible LED. This LED will flash to indicate the progress of the programming sequence. The visible LED flash information is also returned as a status byte to help the host track its progress through the programming sequence.

The ISI number is a three digit code that indicates which type of device is being controlled. Innotech provides a list of ISI-to-manufacturer types. Leading zeros must be included in the programming sequence. For example, to set up the VCR whose ISI number is 045, the “virtual key” sequence is:

Button	LED Flashes
Source 1	1
PROGRAM	2

#0	1
#4	1
#5	1
PROGRAM	3

For hand held remote controls this button sequence is inherently a button press followed by a button release. For the IR engine, the system must send a command with the button-press bit set. When the status byte is returned, it too will have its button-press bit set. The system must then send a button release command and wait for the button-release status byte acknowledge. This is the *flow control handshake*. The 7 LSBs of the button-release command can contain any code. In fact, if the button-press bit is set to 0, the scan code portion of the command is ignored.

The programming sequence to set source #1 to ISI number 045 is:

Button function	Scancode	Status returned
Source1 press	C1 (41 with MSB set)	1 flash
Source 1 release	41 (or 0)	button release
Program press	C0	2 flashes
Program release	0	button release
#0 press	80	1 flash
key release	0	button release
#4 press	84	1 flash
key release	0	button release
#5 press	85	1 flash
key release	0	button release
Program press	C0	3 flashes
Key release	0	button release



In reality, the IR engine will respond to any scancode changes in the command. In other words, it is not really necessary to issue a key

release during the programming sequence. The IR engine will work fine if you issue:

Button function	Scancode	Status returned
Source1 press	0	1 flash
Program press	0	2 flashes
#0 press	80	1 flash
#4 press	84	1 flash
#5 press	85	1 flash
Program press	C0	3 flashes

However, if you do this, the IR engine cannot distinguish two identical consecutive scancodes. In other words if the ISI number were 113, the first two ones could not be distinguished without a button release between them.

Once programmed, the engine will remember the ISI numbers of all the programmed sources until the engine is reset or until it is reprogrammed. You may have up to four different devices programmed and quickly scan between them by issuing a Source # scancode.

The IR engine will respond to programming codes rapidly. At the end of the programming sequence it will provide a status byte that indicates if the

engine accepted the ISI number. (3 flashes)

When infrared is actually transmitted, the status response to the next button may take significantly longer. If an undefined scancode is issued, the device will respond with an error scancode. In addition, if a button that is defined, but is not implemented for the particular device programmed, is pressed the device will respond with a different error response.

Status Byte Format

You will get one and only one status change per command that you send to the IR engine.



Status Byte from IR engine

7	6	5	4	3	2	1	0
Button press	Tx IR	MOD1	MOD0	DAT3	DAT2	DAT1	DAT0

- DB7 ScanKey Up/Down feedback bit
- DB6 Transmitting IR message bit (if continuous)
- DB5-4 MOD bits determine the interpretation of the DAT bits.
 - 0 X Software revision level (5 bits DAT0-3 and MOD0)
 - 1 0 Visible LED flash count
 - 1 1 Status message
- DAT3-0 Status messages (MOD=11)
 - 0000 NOP
 - 0001 This scancode is not used for anything
 - 0010 The selected device is not in the database
 - 0011 This button is not implemented on the selected device.
 - 0100 No source programmed
 - 0101 Programming sequence aborted
 - 0110 IR transmission complete
 - 0111 Database error
 - 1000 IR Engine has been reset
- DAT3-0 LED flashes in BCD (0-9)
- DAT3-0 Software revision code (0-31) Uses MOD0 as a 5th bit.

Assume that the a VCR was previously programmed. Select the source and press the POWER button

- System sends C1h Select VCR source #1
- System gets 21h Return 1 flash
- System sends D2h Transmit IR 2 times mode
- System gets 21h Return 1 flash
- System sends 96h Press the POWER button
- System gets 36h IR Transmission complete (after a delay)

The source selection and transmission instructions stay in effect until they are changed.



Description of Pin Functions

(Includes pin out for DIP and PLCC Package Options)

SYMBOL	PIN		TYPE	DESCRIPTION
	DIP*	PLCC		
Vss	20	22	Input	Ground 0V reference
Vcc	40	44	Input	Power supply +5 Volts
AD0-AD7	39-32	43-36	I/O	Bi-directional I/O data port
RST	9	10	Input	Reset Pin. A 2 μ sec (min) high on this pin resets the PP4001
ENPORT	13	15	Output	Status latch enable (from PP4001)
LED	14	16	Output	Visible programming LED
IR	15	17	Output	IR LED signal
\overline{WR}	16	18	Output	Active low write strobe to status latch
\overline{RD}	17	19	Output	Active low read strobe to command latch
XTAL1	19	21	Input	12 MHz crystal / resonator
XTAL2	18	20	Output	12 MHz crystal / resonator
EA	31	35	Input	External Access Enable

* (DIP available by special order only. Not recommended for new designs.)



ELECTRICAL CHARACTERISTICS

MAXIMUM GUARANTEED RATINGS*

Operating Temperature Range 0°C - 70°C
 Storage Temperature Range -55°C to + 150°C
 Voltage from any pin to V_{SS} -0.5 to V_{CC} + 0.5
 Voltage from V_{CC} to V_{SS} -0.5 to +6.5

*Stresses above those listed could cause permanent damage to the device. This is a stress rating only and functional operation of the device at any other condition above those indicated in the operation sections of this specification is not implied.

DC ELECTRICAL CHARACTERISTICS (T_A = 0°C - 70°C, V_{CC} = +5.0 V ± 10%)

SYMBOL	PARAMETER	MIN	MAX	UNIT	COMMENT
V _{IL}	Input Voltage Low		0.2V _{CC} -0.1	V	
V _{IH}	Input Voltage High	0.2V _{CC} +0.9		V	Except XTAL
V _{OL}	Output Voltage Low		.45	V	I _{OL} =1.6mA
V _{OH}	Output Voltage High	2.4		V	I _{OH} =-60µA
I _{CC}	Power Supply Current		22	mA	12 MHz Clock

