

# SP8001 UNIVERSAL "LEARNING" REMOTE CONTROL INTEGRATED CIRCUIT

## FEATURES

- Fully Integrated Solution
- Controls Common Home Entertainment Devices From Computer or Microcontroller
- Simple serial interface interfaces to computer via conventional UART
- Converts Serial Word into IR
- Controls any combination of TV/VCR/Cable/Satellite receiver
- Combines Innotech's acclaimed remote control code library with powerful IR learning capability
- Retains learned codes even with power removed
- Learns all common IR protocols
- Visible LED and status word outputs for user "handshaking"
- Easy to program
- Punch-Through Operation

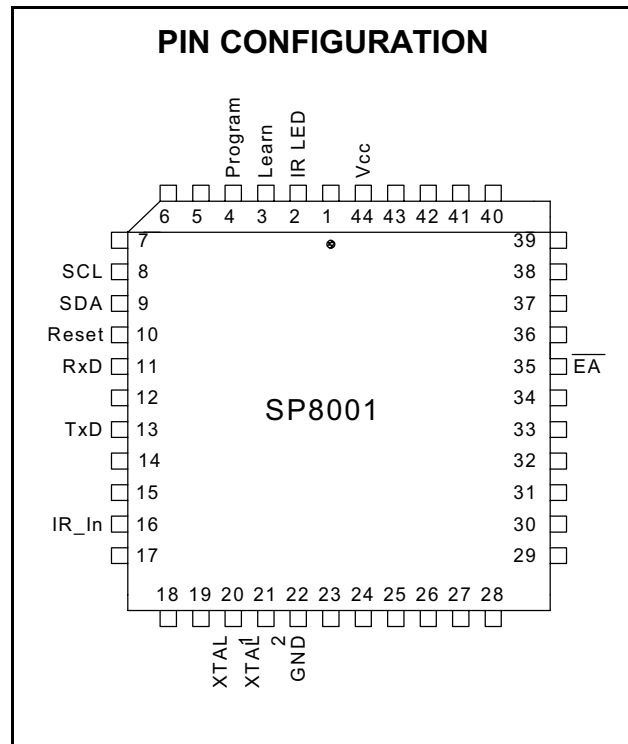

## DESCRIPTION

The ISI SP8001 Serial Port Universal Remote Integrated Circuit provides a convenient means of controlling entertainment devices, such as TVs, VCRs, satellites and cable boxes from a computer or microcontroller. The SP8001 converts serial data words into IR control signals for driving infrared diodes.

The SP8001 includes the comprehensive Innotech library of entertainment remote control codes for the highest possible coverage of consumer products. In addition, the SP8001 can "learn" new

codes from OEM remote controls so that systems incorporating the SP8001 are never out-dated. The learned buttons can be used to add buttons to an entertainment device already in the library, or to add new devices. Learned codes are stored in non-volatile memory.

The SP8001 may be used to control up to six different entertainment devices, of which four are optionally library or learned codes and two are library-only codes.



## DESCRIPTION OF PIN FUNCTIONS

Pin	Symbol	Function	Description
2	IR LED	Output	IR LED output
3	Learn_LED	Output	Visible LED for user feedback during learning (typically red)
4	Program_LED	Output	Visible LED for program set up (typically green)
8	SCL	Input	Input from serial EEPROM used for non-volatile storage of learned codes
9	SDA	Output	Output to serial EEPROM used for non-volatile storage of learned codes
10	Reset	Input	Power On Reset
11	RxD	Input	Serial Input
13	TxD	Output	Status Output
16	IR_In	Input	IR from remote control being learned
20	XTAL1	Output	12 MHz Crystal Connection.
21	XTAL2	Input	12 MHz Crystal Connection.
22	GND	Ground	Ground
35	EA/VP	Input	Connect to +5 Volts
44	VCC	Power	+5 Volts Power Supply

## PROGRAMMING INTERFACE DESCRIPTION

The SP8001 is controlled via a full-duplex bi-directional asynchronous serial interface operating at 2400 baud, 8 data bits, with no parity. A host CPU can manipulate the SP8001 by writing commands in the form of simulated button presses to it. The SP8001 will respond by returning status information for every command.

To maintain flow control, the SP8001 will not return a status response byte until it has processed the previous command.

The command byte consists of 7 scancode bits and one button-pressed bit.



## Command byte to SP8001

D7	D6	D5	D4	D3	D2	D1	D0
Button pressed	Scan Code						

This gives a maximum capacity of 128 buttons. D7, the *button pressed bit*, has several purposes.

- ◆ It provides a way to hold down a button for an arbitrarily long period of time.
- ◆ It provides a flow control mechanism between the two asynchronous processors. Some commands are executed very quickly (10s of microseconds) and some are quite slow (100s of milliseconds).
- ◆ It provides a way to distinguish two consecutive identical button presses.

When D7 is set, the SP8001 recognizes that a button is pressed. D7 is cleared when a button is released. When a command is given as described below, the SP8001 will respond with the same press/release state via the status byte. (See Status Byte Format).

Commands are sent to the SP8001 in the form of keypad scancodes (or “virtual key presses”). The 7 LSBs of the command are the scancode. This gives the system 128 virtual buttons that can be “pressed.” Of these 128 buttons the SP8001 uses a subset to represent the buttons on a typical remote control.

After the SP8001 has received and acted on a command it will return a status byte. The status byte tells the host processor how the previous scancode was dealt with. It also tells the system that it can send another command. The details

of the status byte are covered later in this document.

The SP8001 can be configured to transmit IR messages indefinitely, or it can be instructed to transmit an IR message a fixed number of times and then stop. When sending an indefinite length IR message, a ‘*transmitting IR now*’ status message is returned at the start of a transmission. Subsequently, when a button release command is sent, the SP8001 completes the current transmission and then it returns the appropriate status.

Special scancodes are available to tell the SP8001 to transmit IR message until told to stop, or to send messages a fixed number of times. The auto-repeat range is from 1 to 8 messages. A setting of 0 tells the SP8001 to send the message continuously until the button is released.

When the transmit N times feature is used, the SP8001 will not return a status byte until the IR transmission is completely sent (N times) so that the system knows that the transmission is complete.

The following is a list of scancodes that a system can send to the SP8001. Codes are in hexadecimal and do **not** include the button-pressed bit.



Code	Code	Function	Notes
0	00h	#0	
1	01h	#1	
2	02h	#2	
3	03h	#3	
4	04h	#4	
5	05h	#5	
6	06h	#6	
7	07h	#7	
8	08h	#8	
9	09h	#9	
10	0Ah	ENTER	
11	0Bh	MUTE	
12	0Ch	VOL+	
13	0Dh	VOL-	
14	0Eh	CH+	
15	0Fh	CH-	
16	10h	REWIND	
17	11h	PLAY	
18	12h	FF	
19	13h	RECORD	
20	14h	STOP	
21	15h	PAUSE	
22	16h	POWER	
23	17h	RECALL	
24	18h	TV/VCR	
25	19h	DISPLAY	
26	1Ah	REPEAT	
27	1Bh	RANDOM	
28	1Ch	MODE	
29	1Dh	DISC	
30	1Eh	SEL1	
31	1Fh	SEL2	
32	20h	SEL3	
33	21h	SEL4	
34	22h	SEL5	
35	23h	SEL6	
36	24h	SEL7	
37	25h	SEL8	
38	26h	SEL9	
39	27h	SEL10	
40	28h	UP	

Code	Code	Function	Notes
41	29h	DOWN	
42	2Ah	LEFT	
43	2Bh	RIGHT	
44	2Ch	TRACK UP	
45	2Dh	TRACK DOWN	
46	2Eh	SKIP UP	
47	2Fh	SKIP DOWN	
48	30h	INDEX UP	
49	31h	INDEX DOWN	
50	32h	TRACK	
51	33h	GROUP	
52	34h	PROGRAM	
53	35h	CONTINUE	
54	36h	SNOOZE	
55	37h	TEN PLUS	
56	38h	PWR ON	
57	39h	PWR OFF	
58	3Ah	MENU	
59	3Bh	TITLE	
60	3Ch	CLEAR	
64	40h	PROGRAM	Returns 2, 3 flashes or error code
65	41h	SOURCE 1	Returns 1 flash
66	42h	SOURCE 2	Returns 1 flash
67	43h	SOURCE 3	Returns 1 flash
68	44h	SOURCE 4	Returns 1 flash
69	45h	SOURCE5	Returns 1 flash
70	46h	SOURCE6	Returns 1 flash
71	47h	LEARNirKEY	return status msg 1100
80	50h	Transmit IR continuously until told to stop	(Return 0 flashes)



Code	Code	Function	Notes
81	51h	Transmit IR once	(Return 1 flash)
82	52h	Transmit IR twice	(Return 2 flashes)
83	53h	Transmit IR three times	(Return 3 flashes)
84	54h	Transmit IR four times	(Return 4 flashes)
85	55h	Transmit IR five times	(Return 5 flashes)
86	56h	Transmit IR six times	(Return 6 flashes)
87	57h	Transmit IR seven times	(Return 7 flashes)
88	58h	Transmit IR eight times	(Return 8 flashes)
89	59h	SEARCH (Auto Search)	
90	5Ah	Toggle Punch-through	(Return 1 flash [on], or 0 flash [off])
96	60h	Return firmware major	(Returns 1 flash)
97	61h	Return firmware minor	(Returns 1 flash)
98	62h	Return database revision major	(Returns 1 flash)
99	63h	Return database revision minor	(Returns 1 flash)

SOURCE is used to identify the device being controlled (TV, VCR, Cable etc). SOURCE 1-SOURCE 4 may be used with either library or learned codes. SOURCE 5 and SOURCE 6 are for library codes only. All sources can be associated with any type of device.

Before any IR messages can be sent, the SP8001 must be programmed for the device code of the appliance is being controlled. If you learn a new code, the code will overwrite the library code for the source selected. If you intend to learn a code for a specific source, it is not necessary to program a source code.

The programming sequence for selecting a device code from the IR code library is as follows:

- ◆ SOURCE
- ◆ PROGRAM
- ◆ 3-digit-ISI-number
- ◆ PROGRAM

Two test point leads on the SP8001 are available for connection to visible LEDs. The Program LED flashes to indicate the progress of the programming sequence. The visible LED flash information is also returned as a status byte to help the host track its progress through the programming sequence.

The Learn LED is used to provide user feedback during the learning process. In most applications, this will be a different color LED (such as red) than the Program LED (typically green).

The ISI number is a three digit code that indicates which type of device is being controlled. Innotech provides a list of ISI-to-manufacturer/model types. Leading zeros must be included in the programming sequence. For example, to set up the VCR whose ISI number is 045, the “virtual key” sequence is:

Button	LED Flashes
SOURCE 1	1
PROGRAM	2
#0	1
#4	1
#5	1
PROGRAM	3

For hand held remote controls this button sequence is inherently a button press followed by a button release. For the SP8001, the system must send a command with the button-press bit set. When the status byte is returned, it too will have its button-press bit set. The system must then



send a button release command and wait for the button-release status byte acknowledge. This is the *flow control handshake*. The 7 LSBs of the button-release command can contain any code. In

fact, if the button-press bit is set to 0, the scan code portion of the command is ignored. The programming sequence to set source #1 to ISI number 045 is:

Button function	Scancode	Status returned
SOURCE1 press	C1 (41 with MSB set)	1 flash
SOURCE1 release	41 (or 0)	button release
PROGRAM press	C0	2 flashes
PROGRAM release	0	button release
#0 press	80	1 flash
key release	0	button release
#4 press	84	1 flash
key release	0	button release
#5 press	85	1 flash
key release	0	button release
PROGRAM press	C0	3 flashes
Key release	0	button release

It is not strictly necessary to issue a Key Release command during the programming sequence. The SP8001 will respond to any scancode changes in

the command. The SP8001 will operate properly if you issue:

Button function	Scancode	Status returned
SOURCE1 press	C1	1 flash
PROGRAM press	C0	2 flashes
#0 press	80	1 flash
#4 press	84	1 flash
#5 press	85	1 flash
PROGRAM press	C0	3 flashes

However, in the absence of a Key Release command, the SP8001 cannot distinguish two identical consecutive scancodes. For example, if the ISI number were 113, the first two “ones” could not be distinguished without a button release between them.

The SP8001 will respond to programming codes rapidly. At the end of the programming sequence it will provide a status byte that indicates if the engine accepted the ISI number. (3 flashes)

Once programmed, the SP8001 will remember the ISI numbers of all the programmed sources until the engine is reset or until it is reprogrammed. You may have up to six different devices programmed and quickly scan between them by issuing a Source # scancode.

While infrared is actually being transmitted, the status response to the next button may take significantly longer. If an undefined scancode is issued, the device will respond with an error scancode. In addition, if a button is pressed that is defined, but is not implemented for the particular device programmed, the device will respond with a different error response.

**Status Byte Format**

You will get one and only one status change per command that you send to the SP8001.

## Status Byte from SP8001

7	6	5	4	3	2	1	0
Button press	Tx IR	MOD1	MOD0	DAT3	DAT2	DAT1	DAT0

DB7	ScanKey Up/Down feedback bit
DB6	Transmitting IR message bit (if continuous)
DB5-4	MOD bits determine the interpretation of the DAT bits. 0 X Software revision level (5 bits DAT0-3 and MOD0) 1 0 Visible LED flash count 1 1 Status message
DAT3-0	Status messages (MOD=11) 0000 NOP 0001 This scancode is not currently used 0010 The selected device number is not in the database 0011 This button is not implemented on the selected device. 0100 No source programmed 0101 Programming sequence aborted 0110 IR transmission complete 0111 Database error 1000 SP8001 has been reset 1001 Auto search mode 1010 No learn location specified 1011 No IR detected in learn mode 1100 Press button to specify learn location 1110 Invalid code 1111 Could not learn button
DAT3-0	LED flashes in BCD (0-9)
DAT3-0	Software revision code (0-31) Uses MOD0 as a 5th bit.

For example, assume that a VCR was previously programmed as Source 1. To select the source and press the POWER button:

System sends	C1h	Select VCR (source #1)
System gets	21h	Return 1 flash
System sends	D2h	Transmit IR 2 times mode
System gets	21h	Return 1 flash
System sends	96h	Press the POWER button
System gets	36h	IR Transmission complete (after a delay)

The source selection and transmission instructions stay in effect until they are changed.



## LEARNING CODES FROM EXISTING REMOTE CONTROLS

### LEARNING CODES

To “learn” the codes to add a new device, or to add a button to an existing device:

1. Send the source code for which you wish to store the learned code. (1 flash). (Note: You may learn IR codes only to sources 1-4.)
2. Send LEARNirKEY (Scancode 47h). You will receive a status message 1100. Both the Program and Learn LEDs (red and green LEDs) will now illuminate. (As the learning process is essentially manual, use of the visible LEDs for user feedback is recommended.)
3. Send the button code for the “virtual button” for which you wish to store the learned data. The Program LED will turn off. If no button code is sent you will receive a status message 1010.
4. Hold the original OEM remote control up to the IR sensor. When the code is learned the Learn LED (typically the red LED) will go out and you will receive a 21h return flash (program LED will flash).

If the IR code is invalid or the IR code cannot be learned you will receive a status message 1110. If no IR is detected you will receive a status message 1011.

Repeat steps 2-4 to learn addition buttons for the current source.

*Note: Some OEM remote controls have multiple*

*IR LEADS. It is important to have a direct line between the IR LED on the OEM remote and the IR sensor on the SP8001-based remote control.*

### ERASING LEARNED CODES

Learned functions are associated with the selected source (TV, VCR etc.). To erase learned functions for a specific device (TV, VCR etc.), you overwrite the learned code with a code from the code library. You can erase the complete device; individual buttons cannot be erased.

1. Select the device you wish to reprogram by sending the appropriate Source Code (TV, VCR, Cable etc.). For instance to erase the learned buttons associated with the VCR, send the Source Code you have associated with the VCR.

The Program LED will flash once.

2. Send the scancode for Program (40h).

The Program LED will flash twice.

3. Select a 3-digit ISI device code number from the code list and send the 3-digit code. The Program LED will flash once for each key pressed.

4. Send the scancode for Program (40h) again to lock in the code. The Program LED should flash 3 times. The VCR function will now operate per the selected device code without any learned buttons.



## SPECIAL FEATURES

The SP8001 Universal Remote Control Integrated Circuit has a number of special features:

### Auto Search For Correct Code

#### Overview

If users have trouble programming the SP8001-based system, or can't find the correct code in the manual, the SP8001 can cycle through available codes rapidly to help locate a usable code. It is recommended that this feature be used only when all other methods have failed, as users may have to cycle through many codes before finding a usable one.

1. Manually turn on the device to control.
2. Send the desired SOURCE code.
3. Send PROGRAM.
4. Send SEARCH.
5. When the device turns off, immediately issue PROGRAM

#### AutoSearch Detail

The SOURCE commands provides four alternative search capabilities, permitting the user to save time when performing an AutoSearch:

SOURCE 1 (41h) searches cable boxes and DSS receivers

SOURCE 2 (42h) searches VCRs and DVD players

SOURCE 3 (43h) searches TVs

SOURCE 4 (44h) searches all devices.

When the sequence SOURCE-PROGRAM-SEARCH is entered, the SP8001 will begin transmitting IR codes for all devices starting from the next one currently programmed for that source selection.

The SP8001 will transmit one of 4 different IR codes depending on the button-set encountered for the device being tried. Not every device in the library has a POWER button so the SP8001 will transmit one of the following codes: POWER, CH+, MUTE, or PLAY, depending on which one it encounters first for the current device.

If the SP8001 is set up to transmit IR continuously, (default state or scan-code 50h) it will transmit the test message 4 times. If it is set up to transmit IR from 1-8 times (scan-codes 51h-58h), then it will transmit the programmed number of times for each device.

After the SP8001 transmits the test message, it will wait for 2.5 seconds for the user to respond before it moves on to the next device in the library.

During the 2.5 second interval, if the user presses the PROGRAM button, the SP8001 will accept the current device and program it into the selected slot. The SP8001 will return status message with a flash-count of 3 (status byte 0xA3) to indicate that it accepted the new program.

If the user presses any other key during the 2.5-second interval, the SP8001 will cancel AutoSearch mode and the original programmed device will remain. The SP8001 will return a status message with a flash count of 0 (status byte 0xA0) to indicate that it did not accept any new programming. The SP8001 will also stop



searching and return a 0 flash after it has traversed the entire library.

During AutoSearch, the SP8001 will alternately return a status code 0xF9 (AutoSearch status + transmitting IR bit) at the start of each IR burst, and 0xB9 (AutoSearch status + NOT transmitting IR bit) at the end of the burst. NOTE: The MSB of the status byte can be either 1 (key pressed) or 0 (key not pressed) depending on the last scan code received.

The status bytes returned during AutoSearch mode are the only exception to the rule that every scan code returns one and only one status byte. This was done so that the controlling program can better track the progress of the search.

To review: After the user enters SOURCE<sub>x</sub> - PROGRAM - AUTOSEARCH the SP8001 will immediately return an AutoSearch status & IR transmitting (0xF9) status, followed briefly by AutoSearch status (0xB9) status, followed by the 2.5 second guard delay. It will then repeat this sequence until one of the following occurs...

The user sends PROGRAM to accept the current code (returns 3 flashes).

The user presses any other button to cancel AutoSearch mode (returns 0 flashes).

AutoSearch cancels itself after running through all its codes (returns 0 flashes).

In the case of SOURCE<sub>1</sub>, SOURCE<sub>2</sub>, or SOURCE<sub>3</sub>, it will take about 6 minutes to go through the selected portion of the library. In the case of SOURCE<sub>4</sub> (where the SP8001 transmits all codes), it will take about 18 minutes to traverse the entire library.

The programming sequence to AutoSearch for the code for source #1 is:

Button Function	Scancode	Status Returned
Source1 press	C1 (41 with MSB set)	1 flash
Program press	C0	2 flashes
Auto press	D9	1 flash
The remote control will now search through the library for the target device code in 3 second intervals. Every 3 seconds the user will be prompted by the light flashing and the remote will attempt to turn the power off. When the device turns off, immediately issue:		
program press	C0	3 flashes

The code will be saved. The user should check the other buttons to ensure they all work with the target device. If they do not, repeat the preceding auto search steps.

To stop Auto Search, issue any key code except AUTO.

After the SP8001 is programmed using AutoSearch, you will not know the library code number programmed. See Device Code Read-Back to read back the programmed library code number.

### Manual Search For Correct Code

The user can manually toggle through the library one code at a time to find the correct code for a TV, VCR or Cable/Satellite. Starting from the currently selected device, the SP8001 will begin searching through that same category (TV, VCR, etc.) in the library. This is useful when the POWER button operates the user's equipment, but other buttons do not, indicating the selected code is close but not the same. Using Manual Search, the user can try all the numeric keys, play, stop, etc. to thoroughly test the selection.

The programing sequence is:



1. Manually turn on the device.
2. SOURCE (1-4)
3. PROGRAM
4. 0-0-0
5. Issue PROGRAM as needed. Each time PROGRAM is sent, the SP8001 will increment the device code.

If the current selection does not operate the equipment, you may press PROGRAM and observe 3 flashes. The SP8001 is now set up for the next consecutive device in the library. When you find the correct code, pressing the SOURCE button will save the program setting.

As with AutoSearch, SOURCE1 will scan all cable boxes and DSS receivers, SOURCE2 will scan all VCRs and DVD players, SOURCE3 will scan all TVs and SOURCE4 will scan everything.

The programming sequence to manual search the code for source #1 is:

Button Function	Scancode	Status Returned
Source1 press	C1 (41 with MSB set)	1 flash
Program press	C0	2 flashes
#0 press	80	1 flash
key release	0	button release
#0 press	80	1 flash
key release	0	button release
#0 press	80	1 flash
key release	0	button release
Program press	C0	3 flashes
Key release	0	button release
Each time PROGRAM is sent, the device code will increment. Send SOURCE1 to lock in the code.		

Source1 press	C1 (41 with MSB set)	1 flash
---------------	----------------------	---------

NOTE: Some devices, such as cable boxes, may not support power buttons on the remote. In this case, you can substitute any other supported button to test the code.

After the SP8001 is programmed using Manual Search, you will not know the library code number programmed. See Device Code Read-Back to read back the programmed library code number.

### Device Code Read-back

After the SP8001 is programmed with either Search mode, you will not know the resultant ISI number. To read back the current ISI number, the key sequence is as follows.

SOURCE – PROGRAM - Digit – PROGRAM

Where SOURCE is the slot that you want to read back. (41h - 44h), PROGRAM is 40h, Digit is either 1, 2, or 3 for the Hundreds, Tens, or Ones digit respectively.

The SP8001 will return a flash count of 0 to 9 to indicate the digit.

Example: To read the ISI number of the TV slot

TV(43h)	Return 1 flash (0xA1)
PROGRAM(40h)	Return 2 flashes (0xA2)
1 (01h)	Return 1 flash (0xA1)
PROGRAM(40h)	Return 100s digit of TV e.g. 1 flash (0xA1)
2 (02h)	Return 1 flash (0xA1)
PROGRAM(40h)	Return 10s digit of TV e.g. 2 flashes (0xA2)
3(03h)	Return 1 flash (0xA1)



PROGRAM(40h)      Return 1s digit of TV  
e.g. 5 flashes (0xA5)

Therefore the ISI number of the device in the TV slot is 125.

While in this mode, you can freely go between the 100s, 10s and 1s digits to recount the flashes. To exit this mode, press a source key.

NOTE: You can program any type of device in any of the 6 slots available. For example if you have 2 VCRs you can set one up on the VCR slot and the other in the AUX slot. However, if you use Search, the VCR slot will only scan for VCRs whereas the AUX slot will scan all devices in the library.

### **Punch-Through**

*Availability of this feature varies depending on the type of TV, VCR, and cable box used.*

It can be very convenient to selectively transmit button codes that are not for the currently selected device. For example, when set for Cable box operation, Punch-through can permit the volume commands to adjust the television volume. Similarly, TVs generally do not have a PLAY button but VCRs do. If the last SOURCE button pressed was TV, and the user presses PLAY, punch-thru allows the SP8001 to press PLAY on a source that does have a PLAY button without first switching to it.

The SP8001 defaults to punch-thru being disabled. If a user presses a key that is not implemented on the currently active source, the SP8001 will return an error status (0xB3) that

says that the desired button does not exist. If punch-thru is enable, the PLAY message will be transmitted on the first programmed device that has a PLAY button implemented. You will only get an error if PLAY doesn't exist on any of the programmed sources.

NOTE: If you press a button on a source that isn't programmed yet while punch-thru if off, you will get a No-Device-Programmed Status message (0xB4). However if punch-thru is enabled, and no device has the desired button, you will get a Button-not implemented status message instead.

Punch-thru mode is toggled with scan-code 90 (5Ah).

If punch-thru is toggled ON, the SP8001 will return a 1 flash status message (0xA1).

If punch-thru mode is toggled OFF, you will get a 0 flash status message. (0xA0).

Punch- thru will be affected by learned functions. For example, if you are controlling a VCR and issue a VOL +, the volume command will normally punch-thru to the proper device. However, if you learn a new code onto the VOL+ button, it will no longer punch-thru.

### **DEVICE CODES**

For a code list of supported devices and associated ISI codes, please refer to the document "Index of Device Codes."



## OPERATIONAL DESCRIPTION

### MAXIMUM GUARANTEED RATINGS\*

Operating Temperature Range .....	0°C - 70°C
Storage Temperature Range .....	-55°C to + 150°C
Voltage from any pin to $V_{SS}$ .....	-0.5 to $V_{CC} + 0.5$
Voltage from $V_{CC}$ to $V_{SS}$ .....	-0.5 to +6.5

\*Stresses above those listed could cause permanent damage to the device. This is a stress rating only and functional operation of the device at any other condition above those indicated in the operation sections of this specification is not implied.

### DC ELECTRICAL CHARACTERISTICS ( $T_A = 0^\circ\text{C} - 70^\circ\text{C}$ , $V_{CC} = +5.0\text{ V} \pm 10\%$ )

SYMBOL	PARAMETER	MIN	MAX	UNIT	COMMENT
$V_{IL}$	Input Voltage Low		$0.2V_{CC}-0.1$	V	
$V_{IH}$	Input Voltage High	$0.2V_{CC}+0.9$		V	Except XTAL
$V_{OL}$	Output Voltage Low		.45	V	$I_{OL}=1.6\text{mA}$
$V_{OH}$	Output Voltage High	2.4		V	$I_{OH}=-60\mu\text{A}$
$I_{CC}$	Power Supply Current		22	mA	12 MHz Clock



## TYPICAL APPLICATION SERIAL COMMUNICATION LEARNING REMOTE CONTROL

